

HIGH POWER 6 LED HEADLIGHT FOR 2005-2015 PETERBILT 386 & 1999-2010 PETERBILT 387

Item #35761, #35762, #35763, #35764

NORMAL FOGGING / CONDENSATION

This bulletin provides information regarding headlights that may experience fogging or condensation inside of the headlamp assembly. A drop in air temperature may cause condensation to form on the inside of a cool headlamp lens. Generally, fogging is considered normal and can be eliminated by turning on the headlamp with the engine running for several minutes. In most cases, operating the vehicle in normal driving condition will clear the headlamp fogging. Headlamp assembly replacement **WILL NOT** be necessary in most cases.

NOTE

- If any of the following conditions occur, please consult with a professional mechanic to determine the water source:
 - If condensation/fogging fails to dissipate after operating the headlight with the engine running for 30 minutes
 - If water pooled inside the headlamp
- A high pressure washer may also cause water to be forced into the headlamp assembly.
- Light has non functional dummy plug bulb holder. Please leave this installed to prevent dust and moisture from entering the light.

Connect Plug ① ② ③ to Original OE Wire Harness

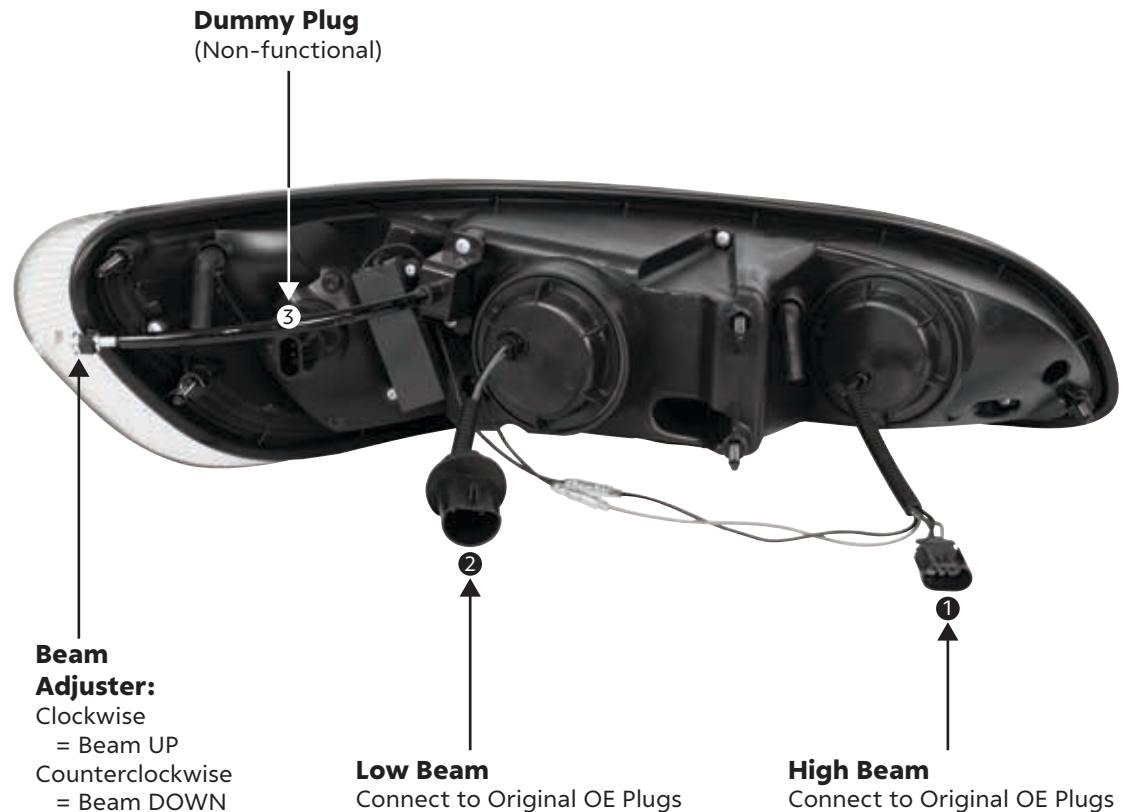

2

1

Connector Pinout Diagrams

Headlight Beam Plug

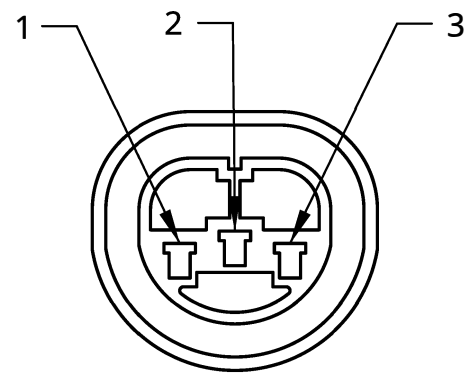

Pin#	Wire	Function	Main Plug Pin#
1	Blue/White	High Beam (+)	4
2	Black	Ground (-)	3
3	Red/Black	Low Beam (+)	5

Parking/Turn Signal Plug

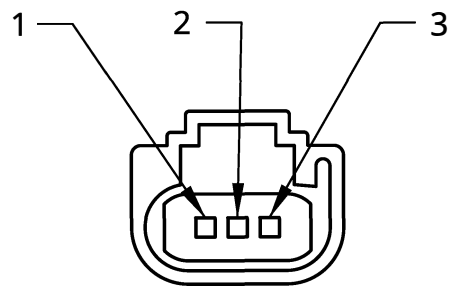

Pin#	Wire	Function	Main Plug Pin#
1	Blue/White	Turn Signal(+)	2
2	Brown	Parking (+)	8
3	Black	Ground (-)	1

Side Marker/Repeater Plug

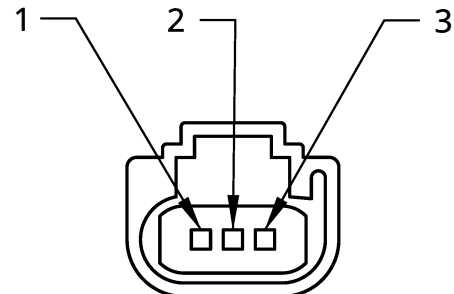

Pin#	Wire	Function	Main Plug Pin#
1	Green	Turn/Repeater (+)	7
2	Brown	Marker (+)	8
3	Black	Ground (-)	6

TITLE			
Peterbilt 386/387 Harness Pinout			
SIZE	DWG NO.	REV.	
A	03212022		
SCALE	WEIGHT	SHEET	
1:1		1 of 2	

2

1

B

B

A

A

2

1

Main Harness Plug

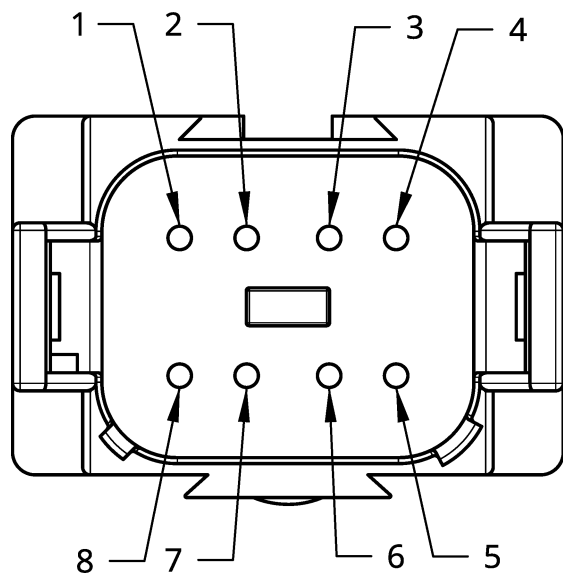

Pin #	Wire Color	Function
1	Black	Ground (-)
2	Blue/White	Turn Signal (+)
3	Black	Ground (-)
4	Blue/White	High Beam (+)
5	Red/Black	Low Beam (+)
6	Black	Ground (-)
7	Green	Turn Signal/Repeater (+)
8	Brown	Marker/Parking (+)

2

1